

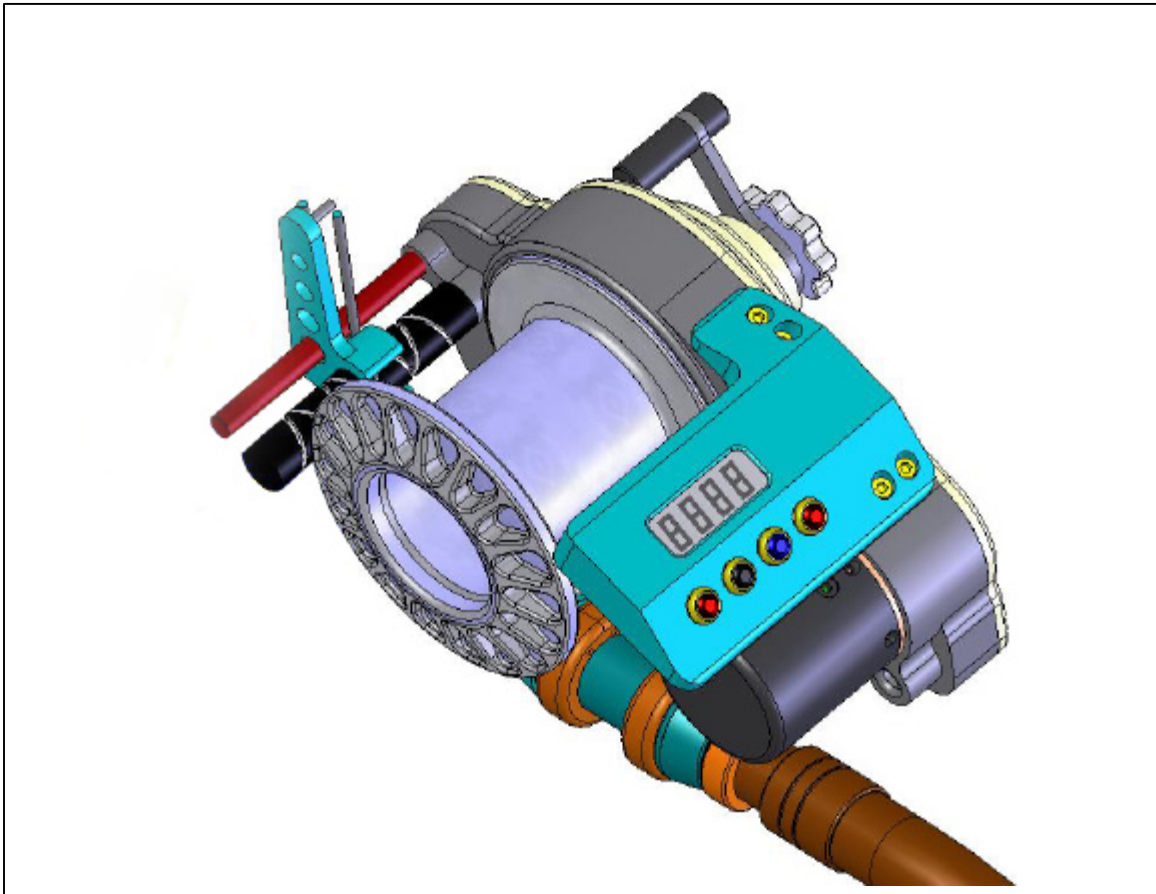

Lindgren-Pitman S-1200 Electric Fishing Reel Instruction and Maintenance Sheet

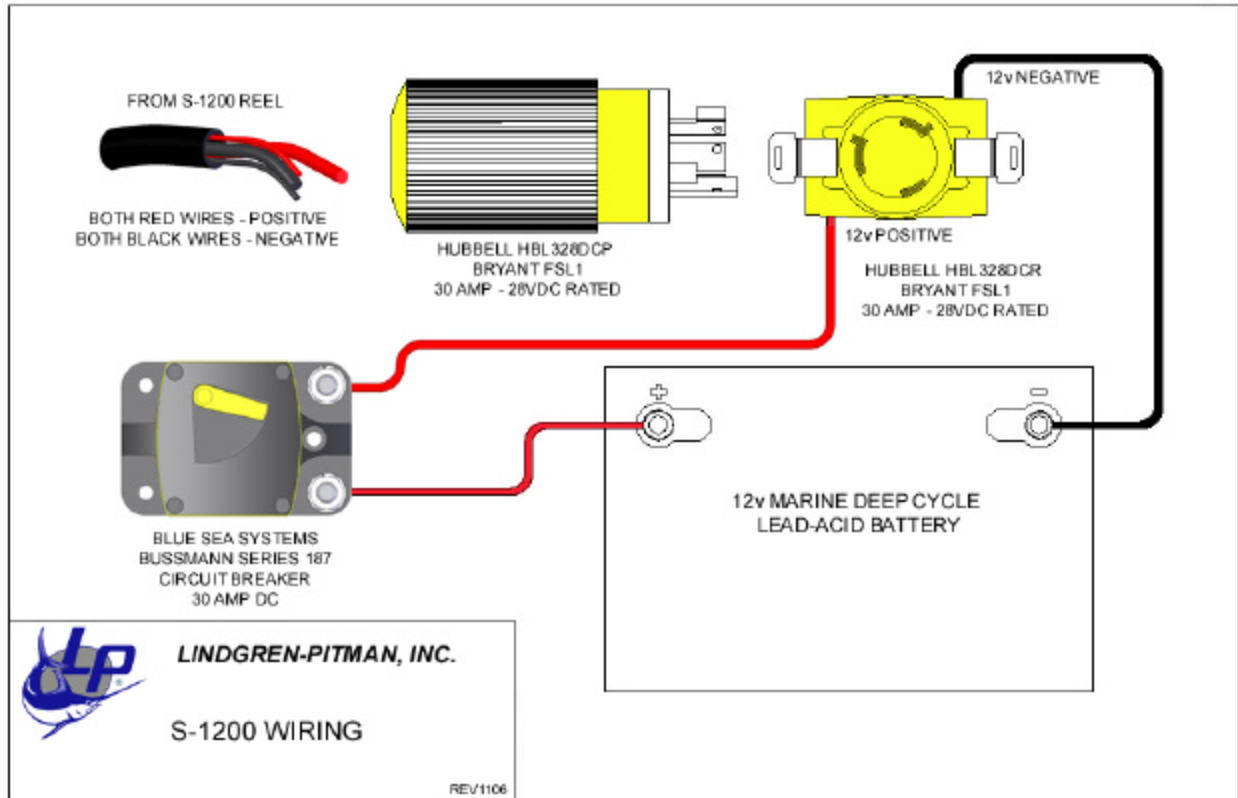

Thank you for purchasing the finest electric reel available. Please read this instruction manual in its entirety before operating the reel. The L/P S-1200 is an investment that if taken care of, should provide many years of fishing.



Power Requirement and Wiring: 12-volts DC Max 30Amps
 Plug – Hubbell #HBL328DCP Available Receptacle – Hubbell #328DCR

Use a minimum of **8 gauge or thicker tinned wire** between the battery and receptacle with a **30 amp resettable breaker or 50 amp slow blow fuse** on the positive side as close to the battery as possible. A **Hi-Amp Buss swing arm breaker** with a manual trip push button is available from you local marine store or from Lindgren-Pitman. The red wire is the positive, the black is the negative. **PLEASE NOTE:** do not shorten the length of the reels cord – it will void the warranty. The reel will work with a standard lead acid marine duty deep cycle battery. To ensure you do not deplete the battery used to start your boat, the S-1200 should be powered from a separate accessory battery that can be switched via a battery switch.

Mounting:

The S-1200 weighs approximately 20 pounds with an empty spool. Please take into account the load requirements that your rod holders can handle. We recommend that at the very minimum your existing holders should be bracketed to the gunnel. Lindgren-Pitman, Inc. manufactures an optional rod holder bracket suitable for mounting this reel. As with any reel be sure it is tethered to the boat in case it breaks free from the rod holder, a hole is provided in base clamps to facilitate this.

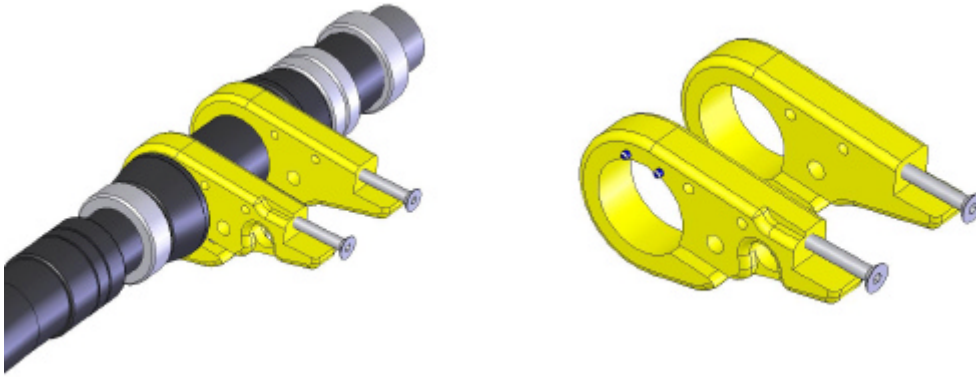

The S-1200 is supplied with L/P reel base clamps shown above (the rod and rod butt are shown for illustration purposed only and are not included) with either 80 (1.343" diameter) or 130 (1.565" diameter) rod butt mounts to be specified at the time of purchase. Rod butt clamps use locating pins that fit inside a standard AFTCO® rod butt and are used to position the clamps and to keep it from rotating on the rod. First install the two clamps to the reel with the supplied 5mm screws (do not tighten). Put the rod butt through the clamps securing the rear rod clamp (the one with the hole for the line tether) first into the locating pins and tighten the clamp. Next install the forward rod clamp. Now once both clamps are on and aligned tighten the 5 millimeter allen screws that secure the mount to the butt. Now tighten the 5mm clamp screws that were left loose. Note: the rod clamp that has the hole for securing a line tether is to be mounted towards the bottom of the rod butt.

Loading the Spool:

Typically the line of choice will be preloaded on the spool by the retailer. If not already done it can be easily accomplished with a 12-volt DC power source such as a standard automotive battery. **WARNING: never use a battery charger to run the S-1200 as the power is not clean and it can damage the circuitry and void your warranty.** Because of the materials used, the nylon or titanium spools do not require backing. When loading the spool it is necessary to use the level winder to establish the correct track for the line. Once it has been fully loaded the level winder will always follow the same track keeping the line perfectly wrapped.

If for any reason a spool is changed the same spool loading procedure must be followed. When the spool is mounted make sure the position of the level winder matches the location of the line on the spool. If it the line does not align with the level winder, loosen the drag and manually rotate the spool until the level wind matches up with the line working in the same direction as the line wrap on the spool. Pay special attention during the first drop to be sure the line and the winder stay in-sync.

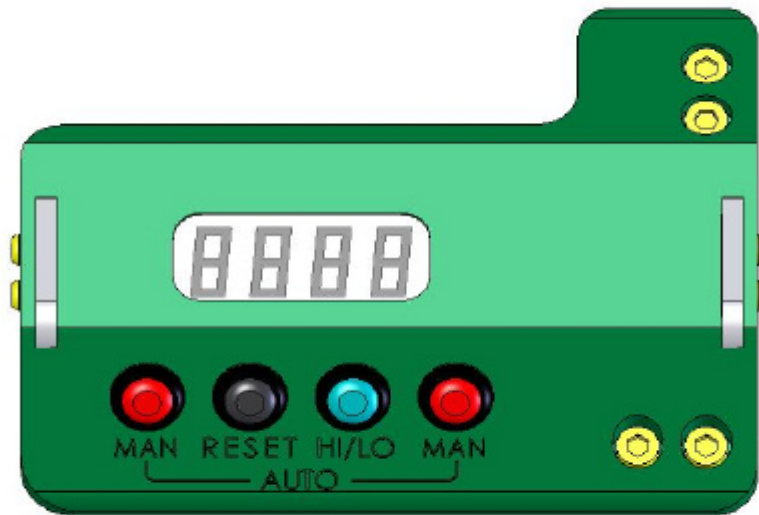

CONTROL PANNEL BUTTONS

Reset Button

This button zeros the counter. The “stop at zero” feature uses this as the reference point to turn the reel off. **WARNING: Never push the reset button without first setting the rig at least 20 feet below the top of the pole. Failure to do this could cause the fishing rig to retrieve past the tip and the possible loss of gear and fish.**

Manual Retrieve Buttons

Pushing either one of the “man” buttons turns the reel on as long as the button is held down. Once the button is released the spool stops. This is used to advance the reel manually. This is especially useful after using the “stop at zero” feature to slowly bring the gear to the boat. It can also be used to retrieve the rig if the “stop at zero” feature is not used or the reset button is accidentally pushed.

Stop at Zero is activated by pushing both of the man buttons together for at least two seconds. This is one of the handiest features of the S-1200 as it makes for truly “hands free” retrieval. **WARNING:** Once the “stop at zero” feature is activated it runs the reel until the counter hits 0000. **IMPORTANT:** If at any point the reel needs to be stopped push either of the red “man” buttons. The “stop at zero” can be continued by pushing both “man” buttons again at the same time for two seconds and the reel will continue to 0000.

Hi-Low 2-Speed Button

The S-1200 can operate in two speed settings, hi and low. This is done by pushing the hi-low button while the reel is running. Typically the reel will spend the majority of the time in high speed. The low speed is used under heavy loads as it cuts the amperage draw and makes for less slipping of the drag. It is also useful as the counter approaches zero to slow the gear down.

Harness Lugs:

The top of the control panel incorporates two harness lugs that allow the angler to secure the reel to their choice of harness.

Using the S-1200:

Once the wiring has been routed and the reel is mounted the S-1200 is ready for service. As with any other instrument a little practice will make its use second nature. Plug the cord into the receptacle and backlight will illuminate the display reading 0000. Begin by releasing the drag and pulling the lever towards you, “free spooling” the line about 20 feet. Push the reset button to set the counter to zero. The counter only counts the number of revolutions of the spool and is an approximate measurement of feet. The actual payout varies by the amount and diameter of line on the spool and the stretch of the type of line being used. This is why you should always “free spool” some line prior to setting the counter to allow for a margin of safety when using the auto retrieve.

Once the counter has been reset release the drag again and notice the counter numbers increasing as the line leaves the spool. While free spooling adjust the drag so it pays out at a nice even speed. This is the first stage of the 2-stage drag system incorporated into the S-1200. It offers a very light drag for the first travel of the drag lever. When you notice there is no more tension on the line adjust the drag allowing for the line to continue traveling on the ocean floor. Look for short movements on the rod indicating fish are on. Once you have decided to retrieve the rig press both red buttons marked “man” for manual and hold them down together for at least two seconds. The reel will begin to retrieve the line until the counter reaches 0000. Once this happens the reel shuts off. To get your rig to the top of the pole press either of the “man” buttons which manually retrieves the line as long as the button is pushed. Once the rig is to the top of the pole the same procedure can be repeated over and over again.

Changing the Spools:

As already mentioned the cantilever spool design makes line changes easy. Optional nylon and/or titanium spools can be purchased that can be used to hold back-up or alternate line sizes and types. To remove the spool loosen and remove the 4 stainless steel hex head screws inside the spool hub with a 5 millimeter allen key. Make sure when replacing the allen screws that they have a good coating of anti-seize compound such as “Teff Gel” to prevent corrosion and make future changes easy. Follow the procedure for line alignment with the level winder under the “Loading the Spool” section above.

S-1200 Features:

- High Power “state-of-the-art” 12-VDC motor operation
- Electronic control and switching.
- Backlit electronic counter
- Stop at zero mode
- Simple easy to use controls
- Hands off hauling
- Gear driven level winder
- Ergonomic cantilever design
- Optional titanium spool endures any type or size of fishing line
- Hard coat anodized aluminum alloy construction
- Changeable spool design
- 2-Stage drag system
- External preset drag vernier control
- Smooth wide span drag control (over 180 degrees)
- 0 to 60 lb. plus drag capability
- Designed to endure continuous fishing in deep water for large fish
- All line usable spool design
- High line capacity spool

*Approximate line capacity

MM	Inches	Yards	Example
.8	.031	2000	1200 +++ 200 lb. Hi tech fiber line
.9	.035	1500	1000 yds 100 lb. Test wire line
1.0	.039	1200	100 lb test monofilament
1.2	.047	880	2.2 lbs of 150 – 175 lb test monofilament
1.4	.055	650	2.2 lbs of 225 – 250 lb. test monofilament

Maintenance:

Treat the S-1200 the same as you would of any other high quality marine electronic component. While the S-1200 is completely sealed care should be taken to minimize its exposure to the salt water environment. If possible, remove the reel from the rod holders when not in use. Always rinse the reel with fresh water and thoroughly dry. The case is made from aluminum and is hard anodized to prevent corrosion, it does not require any special care beyond that noted. The nylon and titanium spools will not react with any type of line used and require no maintenance. The display bezel is glass and is very durable but be careful not to place any weight on the glass or let anything hit it as it could shatter. NEVER use abrasive cleaners on the S-1200, just soap and fresh water. Before any outing test the reel prior departure to be sure all of the features are functioning correctly.

Every season the reel should be thoroughly inspected for any damage or corrosion. Inspect the cord for any cuts and inspect all of the electrical terminals, they should be free of corrosion.

Current Overload Protection:

The S-1200 has three protection circuits to prevent the reel from drawing too much current. It has a factory set maximum drag as a first line of protection. If for any reason this is bypassed and the reel stops operating under load, the current limiting safety has more than likely been triggered. Simply push either of the man buttons twice and it will reset the reel and it should continue running. If this still does not work unplug the reel and let it set for approximately one minute without power. This clears the software and the reel should continue to function.

Service and Storage:

Should you notice any loss in performance or have any problems operating the S-1200 it should be returned to Lindgren-Pitman, Inc for evaluation. There are no parts inside the reel that can be serviced except by factory technicians. **All parts are fit to exacting tolerances and any attempt made to open either the case or display will void the warranty.** If for any reason any of the bolts need retightening, all hardware is metric. It is recommended that the reel be stored in a warm and dry space such as the engine room. Storage in the salon or other air conditioned room onboard can be detrimental due sudden changes in temperature and humidity that can cause condensation inside the reel. For long term storage it is recommended that the S-1200 is kept in a secure temperature controlled room off of the boat. **Important Note: Always store the reel with the drag released, this will ensure the drag springs do not loose their compression tension.**

Warranty:

The S-1200 is warranted to be free from defects in materials or workmanship for one year from the date of purchase. Within this period, Lindgren-Pitman, Inc. will, at its sole option, repair or replace any component which failed in normal use. Such repairs or replacement will be made at no charge to the customer for parts or labor, provided that the customer shall be responsible for any transportation cost. This warranty does not cover failures due to abuse, misuse, accident or unauthorized alterations or repairs.

THE WARRANTIES AND REMEDIES CONTAINED HEREIN ARE EXCLUSIVE AND IN LIEU OF ALL OTHER WARRANTIES, WHETHER EXPRESS, IMPLIED OR STATUTORY, INCLUDING ANY LIABILITY ARISING UNDER ANY WARRANTY OF MERCHANTABILITY OR FITNESS FOR A PARTICULAR PURPOSE, STATUTORY OR OTHERWISE. THIS WARRANTY GIVES YOU SPECIFIC LEGAL RIGHTS, WHICH MAY VARY FROM STATE TO STATE.

IN NO EVENT SHALL LINDGREN-PITMAN, INC. BE LIABLE FOR ANY INCIDENTAL, SPECIAL, INDIRECT OR CONSEQUENTIAL DAMAGES, WHETHER RESULTING FROM THE USE, MISUSE OR INABILITY TO USE THE PRODUCT OR FROM DEFECTS IN THE PRODUCT. SOME STATES DO NOT ALLOW THE EXCLUSION OF INCIDENTAL OR CONSEQUENTIAL DAMAGES, SO THE ABOVE LIMITATIONS MAY NOT APPLY TO YOU.

Lindgren-Pitman, Inc retains the exclusive right to repair or replace the product or offer a full refund of the purchase price at its sole discretion. SUCH REMEDY SHALL BE YOUR SOLE AND EXCLUSIVE REMEDY FOR ANY BREACH OF WARRANTY

Accessories:

L/P Wiring Kit (Hubbell box, 20' of 8 gauge wire and Buss breaker)
Rod Holder Support Bracket
DC to DC Power Converter Box – 24 volts to 12
110 Volt Portable Power Supply

Once you receive your S-1200 please register it by emailing Lindgren-Pitman, Inc. at sales@lindgren-pitman.com with your name, address, phone number along with the serial number(s) of the reel you purchased. This way we can keep you up to date with future Lindgren-Pitman products.

The S-1200 is protected by Both Domestic and Foreign Patents Pending

Manufactured in the U.S.A

Lindgren-Pitman, Inc.
2615 N.E. 5th Avenue
Pompano Beach, FL 33486
Phone (954) 943-4243 Fax (954) 943-7877
Email: sales@lindgren-pitman.com
www.lindgren-pitman.com