



# **LINDGREN-PITMAN, INC.**

## **Super Spool III**

### **Installation Instructions**



**LINDGREN-PITMAN, INC.**  
2615 N.E. 5th Avenue \* Pompano Beach, Florida 33064 \* U.S.A.  
(954)943-4243 \* (954)943-7877 Fax  
E-mail: [longline@gate.net](mailto:longline@gate.net)  
<http://www.lindgren-pitman.com>

# Installation instructions for Lindgren-Pitman Super Spool III

## LOCATION

A location must be selected that assures crew safety and efficient hauling and setting of the line. If assistance in choosing a mounting location is required consult the factory or your local dealer for assistance. The foot print dimensions for LP super Spool III can be found in Appendix A or obtained from the factory.

Sufficient distance should be maintained between the spool level winder and the pulley or roller preceding the level winder to reduce level winder stress and maintenance. Please note that a distance equal to the spool travel (width of spool) should be the minimum distance allowed between the fairlead/roller assembly and the hauling block. The hauling block must be centered in relation to the main spool.

## MOUNTING

For steel boats angle or channel brackets should be welded to the deck that allow for through bolting to the spool feet. Insulators must be placed between steel or stainless steel brackets and the aluminum feet to reduce electrolysis. Lindgren Pitman optional mounting bracket P/N KIT-MOUNT-PLATE has 4 stainless steel brackets with mounting holes suitable for proper installation. Care should always be taken to prevent fires when welding mounting brackets to decks.

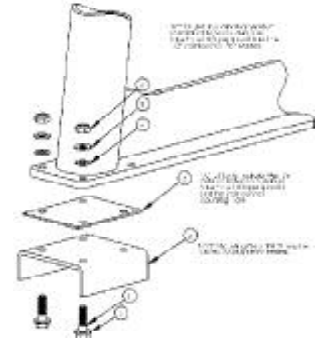

Fiberglass and wooden boats may use suitable lag bolts or through bolts.

Decks should be inspected to assure that they are adequate to support the weight of the spool and monofilament.

## HYDRAULICS

Lindgren-Pitman long line reels must be installed with a manifold and remote control valve assembly designed for each model. This assembly includes pressure relief's, anti-cavitation motor protection and line setter feedback control circuit. The standard valve has pressure compensated flow control with a preset maximum of 12 GPM to the motor circuit. The circuits will allow for up to 15 GPM pump flow.

The valve assembly is designed to be remote operated by standard 33 C marine throttle / shift type mechanical cables. This allows for the valve assembly to be mounted below decks to reduce maintenance and installation cost. The valve assembly should be located to minimize hydraulic line lengths and be located in a dry location. Final adjustment of the control lever should be done to utilize as much of the control lever rotation and travel as possible for full valve operation.

Lindgren-Pitman offers packaged hydraulic systems with electric or engine driven pumps. These systems have the valve assembly mounted to the oil reservoir and are as pre piped as possible to minimize field installation. If Lindgren-Pitman packaged hydraulic systems are not used hydraulic supply requirements are as follows:

### Pump Requirements:

48" reels	12 GPM	1500 psi
40" reels	11 GPM	1700 psi

### Hoses Requirements:

Hydraulic hoses should be #12 JIC with a pressure rating of 3500 psi

Control Valve to Motor	3000 psi /200 Bar
Pump to Valve	3000 psi /200 Bar
Control Valve to Line Setter (if Line Setter is used)	1500 psi /100 bar
Return to Tank	500 psi /30 Bar

**ACCESSORIES**

**Lindgren-Pitman Line Setters LS-3, LS-4, LS-5**

Lindgren-Pitman line setters are designed to be compatible with Lindgren-Pitman long line reels in series hydraulic circuits so no additional pump is required. The output of the long line reel control valve can be connected directly to the input of the line setter.

**Fish Hoist or other**

Fish hoist or other accessory may be included in the same hydraulic circuit. The control valve for any accessory must be installed in the circuit between the pump and the spool control valve so that it can not create additional backpressure on the spool control circuit.

**START UP**

All connections should be checked for correctness and tightness prior to operating the pump. Operate the pump for several minutes before operating the control valves. Use this time to inspect closely for any leaks. During this time the system will purge itself of most air. Operate each piece of equipment slowly to further purge air from the system and allow motor cases to fill with oil. Further test all equipment for proper operation

**ADJUSTMENT**

Lindgren-Pitman long line reel valves and assemblies are factory adjusted and will operate in most applications as shipped. Factors such as system back pressure and customer preferences may require adjustments. If adjustments are necessary follow procedures in Appendix B

**NOTE: Failure To Use The Supplied Main Spool Control Manifold Will Void Warranty.**

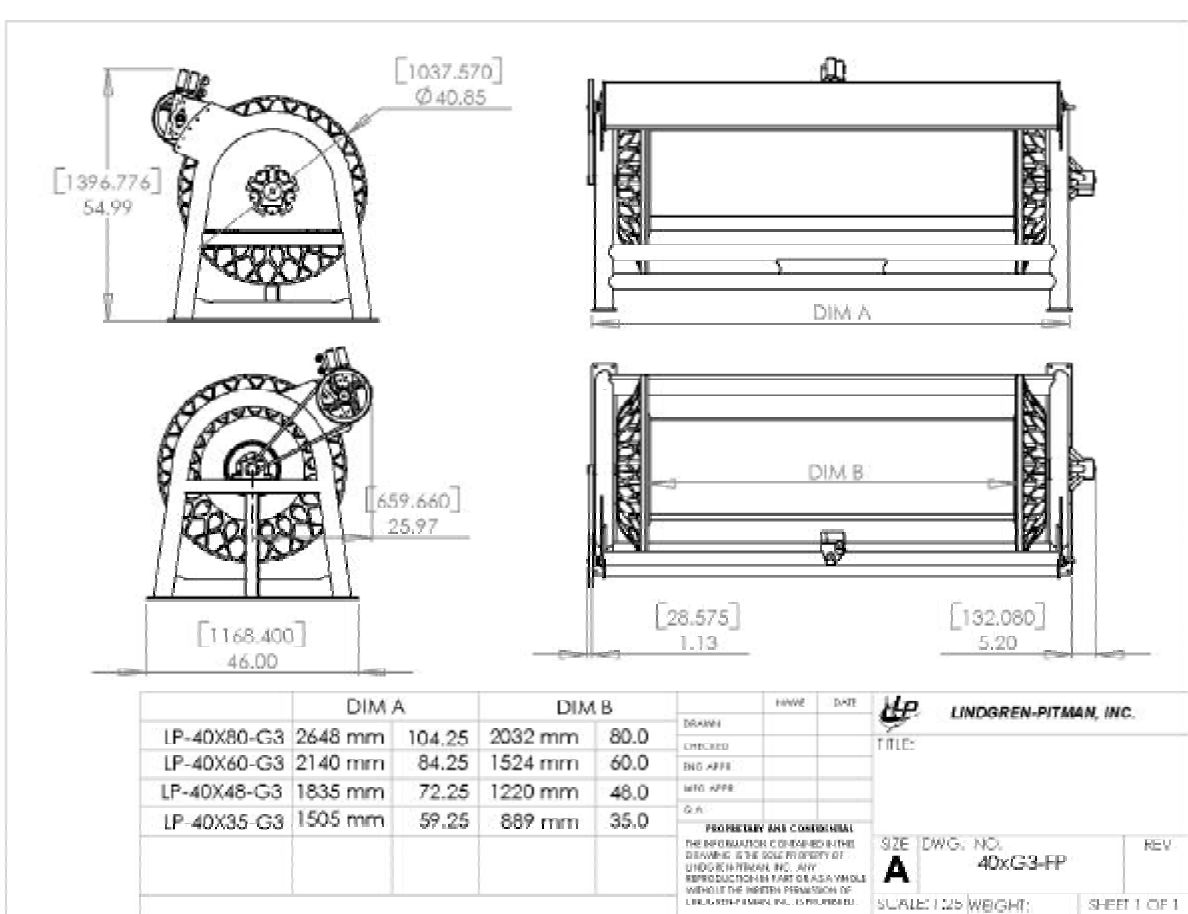

## Appendix B

### HYDRAULIC SPECIFICATIONS AND ADJUSTMENTS FOR SERIES III SYSTEMS

Series III line setters and long line spools have an improved hydraulic system that will operate more smoothly, more efficiently and with fewer adjustments than previous hydraulic systems. Many hydraulic systems will not need any adjusting after installation.

Hydraulic system piping should be designed to minimize backpressure losses to 250 psi if possible. For most systems 3/4 inch pipe or hose will suffice unless flows are higher than 12 GPM or lines are extremely long. Pressure drops for many sizes are shown in the appendix.

An additional valve can be added to the hydraulic system for a fish or anchor hoist, but it must be in series with the Lindgren-Pitman supplied valve assembly and the backpressure must be measured at the input of the supplied valve assembly to use the recommended settings.

#### FACTORY SETTINGS

DESCRIPTION	NUMBER	SETTING (psi)
System Relief		125 lbs. pull - full spool or 40 Diameter 1300 psi + back pressure 48 Diameter 1100 psi + back pressure

#### SPOOL MANIFOLD

Counterbalance (See list Pg. 2)	A207 10Q C04	40-inch diameter spools 1600 psi 48-inch diameter spools 1300 psi
------------------------------------	--------------	--



ANTI-CAV. BIAS	PRDB	150 - 200 psi - 1 turn CCW
----------------	------	----------------------------



Braking Relief	RPGT	3000 psi - 1/4 turn CW from full CCW
----------------	------	--------------------------------------



#### LINE SETTER MANIFOLD

Line Setter Relief	RVGB-LCN	1000 approx. 2 1/2 turns CW from full CCW or 70 lbs. pull.
--------------------	----------	---



In some cases especially, where hydraulic systems have more than 250 psi back pressure adjustments may be necessary. Making adjustments accurately will require gages installed. In many cases counting the turns on a valve, which will give an approximate setting, can make adjustments.

Determine system backpressure by putting a pressure gage directly at the input of the valve assembly supplied by Lindgren Pitman if no additional valves have been added to the system this should be measured at the output of the pump. A 2000 or 3000 psi maximum gage is suitable. If the backpressure is over 200 - 250 psi the main spool may not break properly when operated with a line setter unless the counterbalance is adjusted to a higher setting by turning the adjustment counterclockwise. The new setting should be enough to offset the backpressure losses approximate settings are as follows:

Counterbalance  
A207 10Q C04

Braking Relief  
RPGT-LWN

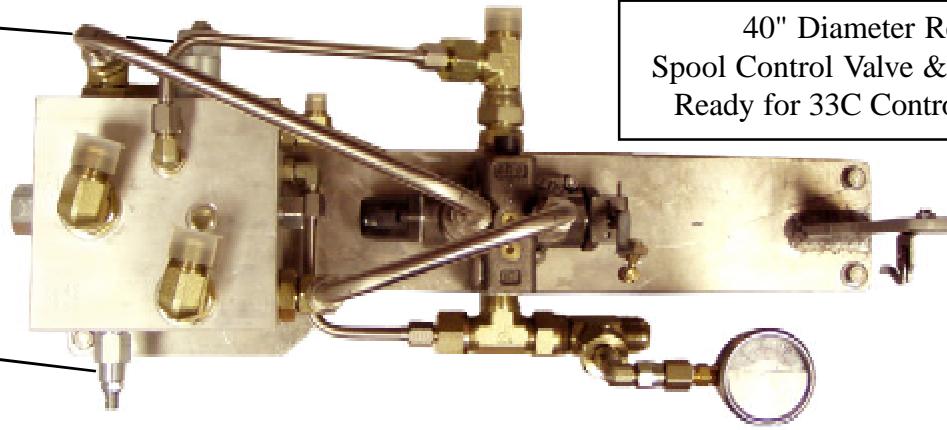

40" Diameter Reel  
Spool Control Valve & Manifold  
Ready for 33C Control Cable

#### 48 INCH DIAMETER LONG LINE REELS

Backpressure	Turns from full CW A207-10Q-CO4
200 psi	1 1/2
300 psi	2 1/2
400 psi	3 1/2
500 psi	5
600 psi	6 1/2



The counterbalance (A207 10Q C04) can be set accurately by preventing the spool rotation and then actuating the control valve in the hauling direction and adjusting counterclockwise to increase or clockwise to decrease the pressure. Read pressure at gage port GL or tee into port ML.

Line setter power relief (RVGB - LCN) can be adjusted by threading the line setter and tying the input line to a fixed point. Turn on the line setter and read the pressure in the pilot feedback line. Adjust to 1000 - 1300 psi clockwise - increase and counterclockwise decrease. Pilot pressure is the gauge reading minus the system back pressure.

Braking in the hauling direction is adjusted by setting the RDDA valve on the spool manifold. Operate the spool at full speed and then move valve to center to brake. Read braking relief at port GR or tee into port MR. Do not set over 3700 psi. Make sure hoses or pipes are pressure rated for your setting or higher.

Counterbalance  
A207 10Q C04

Braking Relief  
RPGT-LWN

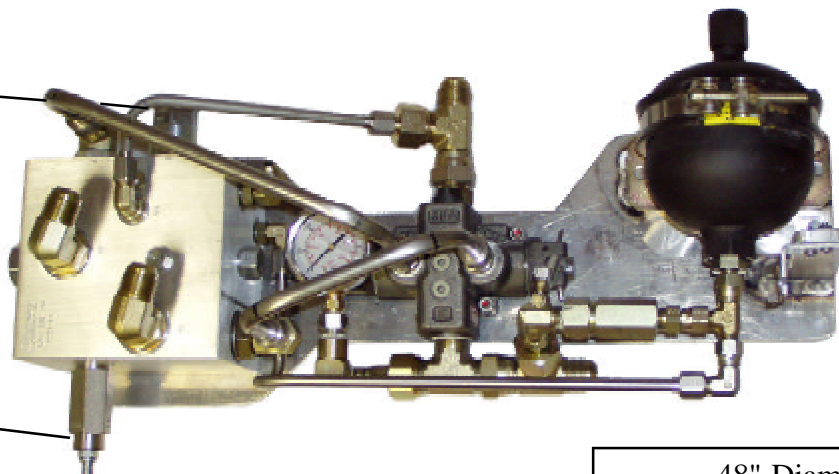

48" Diameter Reel  
Spool Control Valve & Manifold  
Ready for 33C Control Cable





## Hydraulic Circuit Main Spool Manifold - Series III

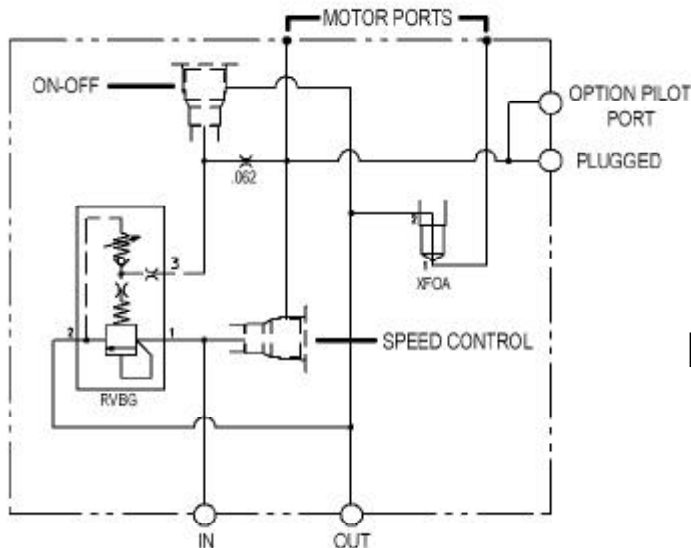
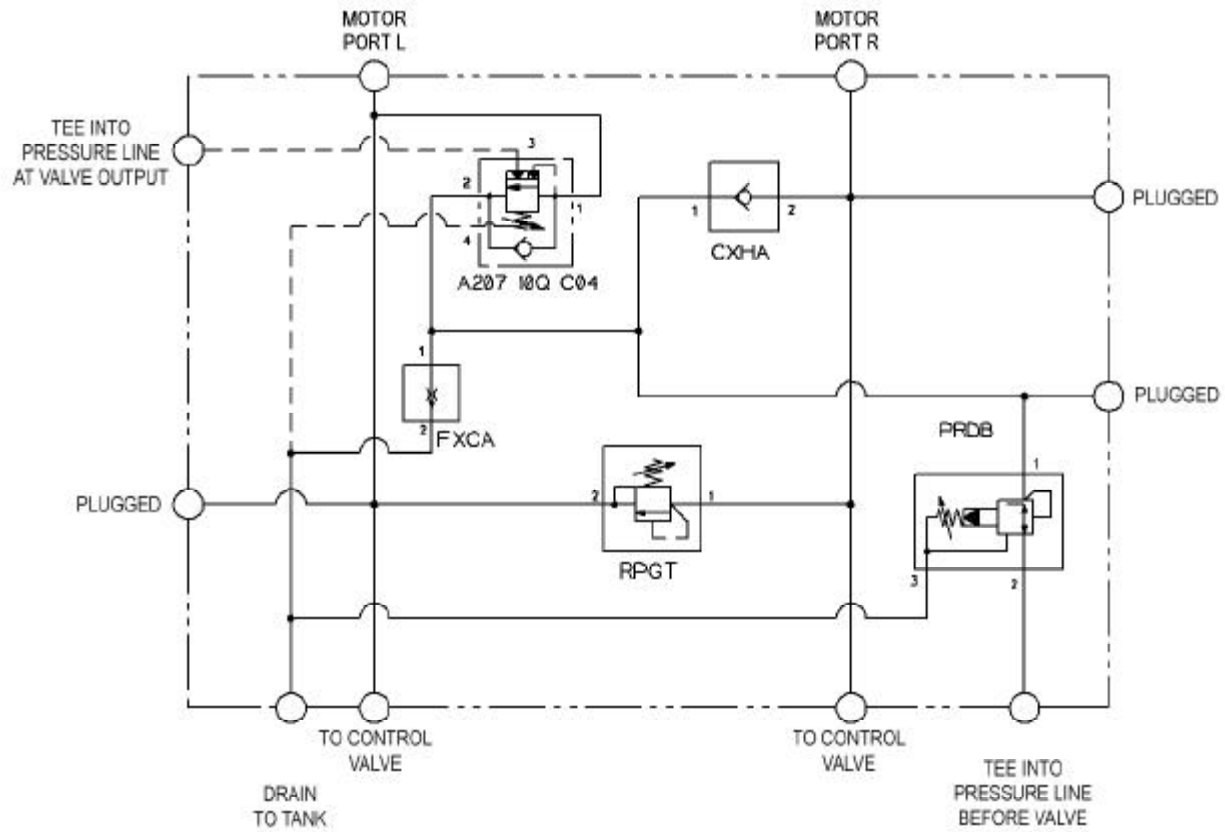

## Hydraulic Circuit LS-5 Line Setter Manifold

# 40" Diameter Reels

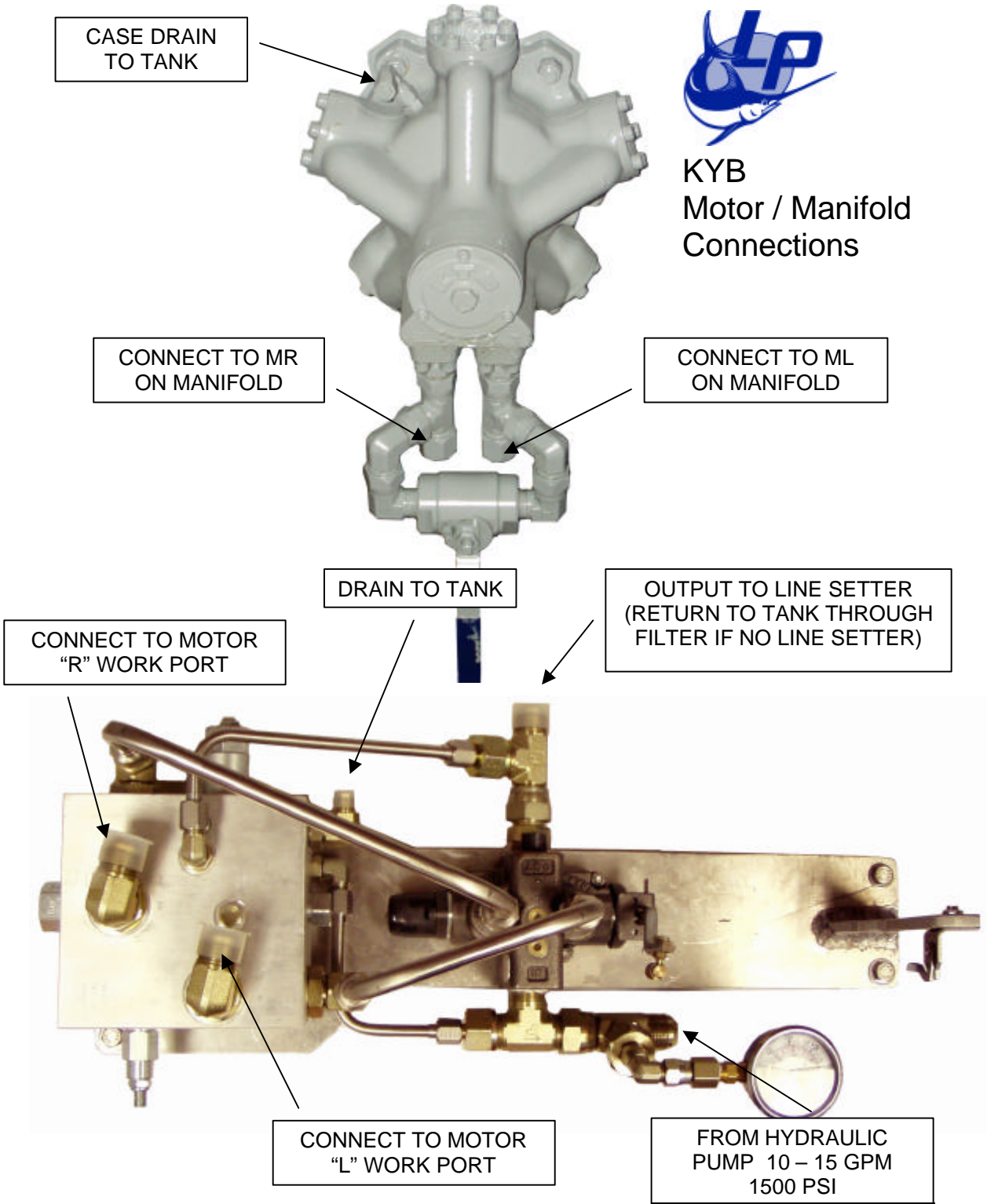

# 48" Diameter Reels



Poclair  
Motor / Manifold  
Connections

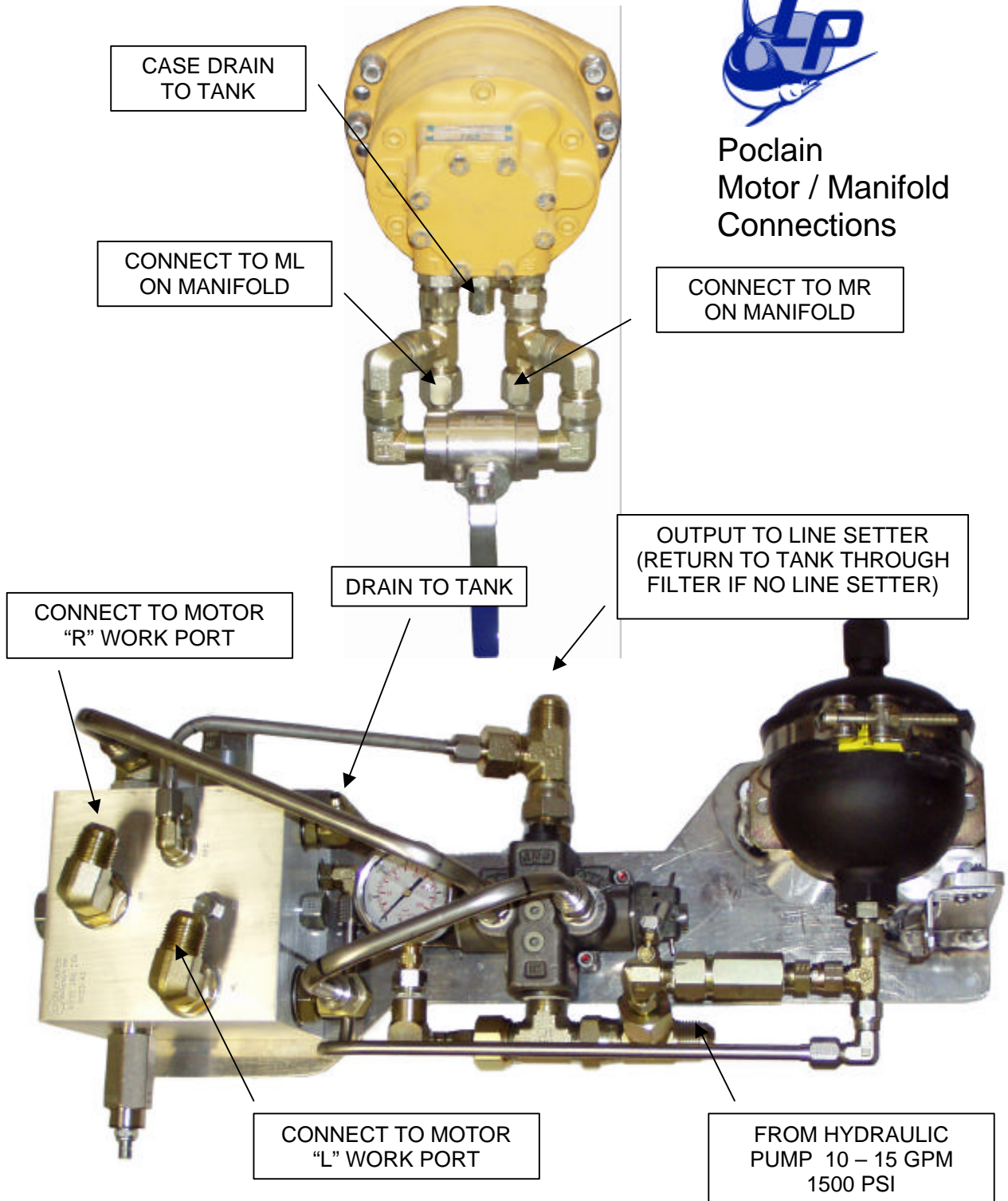



**LINDGREN-PITMAN**  
**Super Spool III**  
**Longline Spool Hydraulic Power Unit**

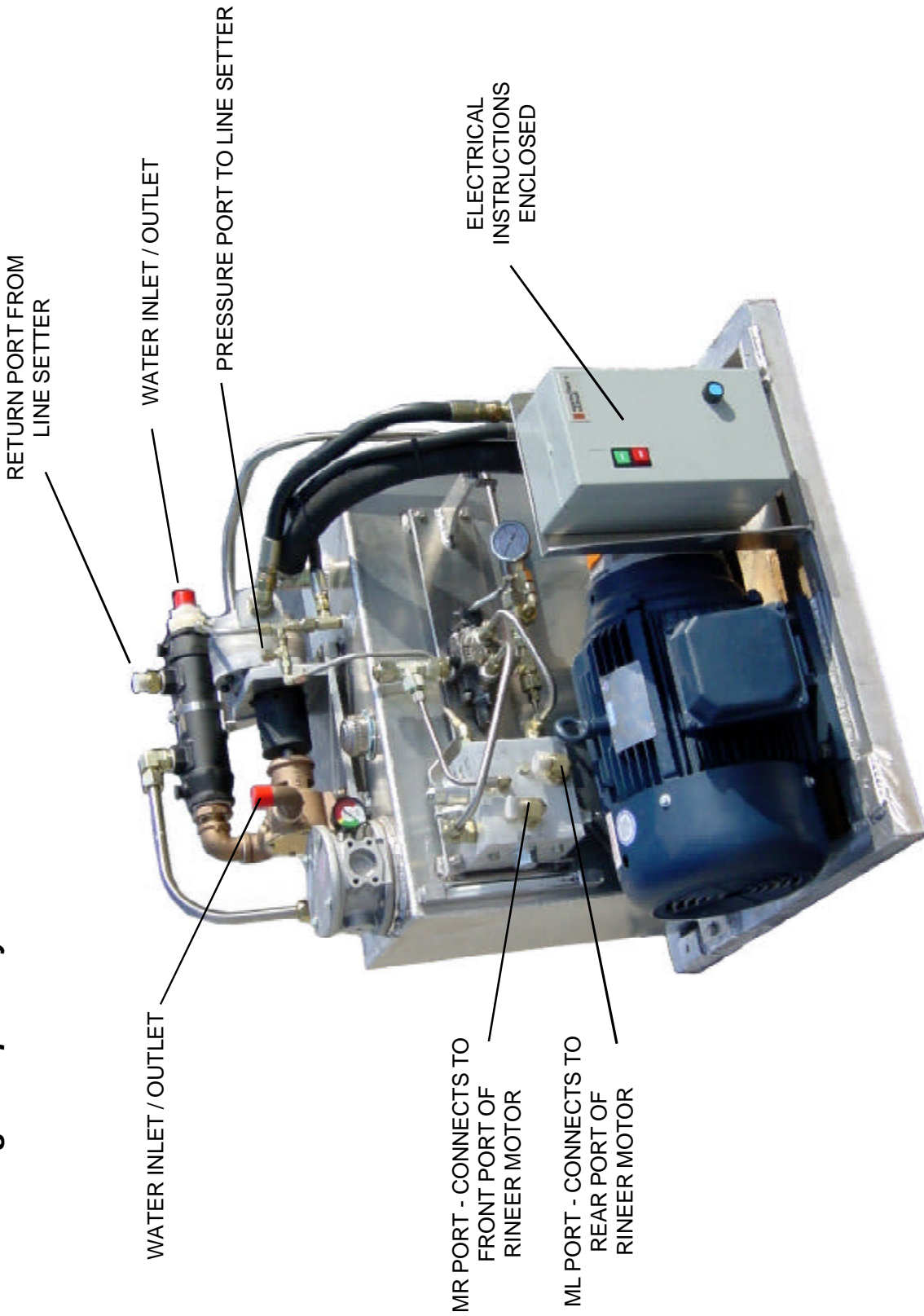

**LINDGREN-PITMAN**  
**Super Spool III**  
**Longline Spool Hydraulic Circuit Connections**

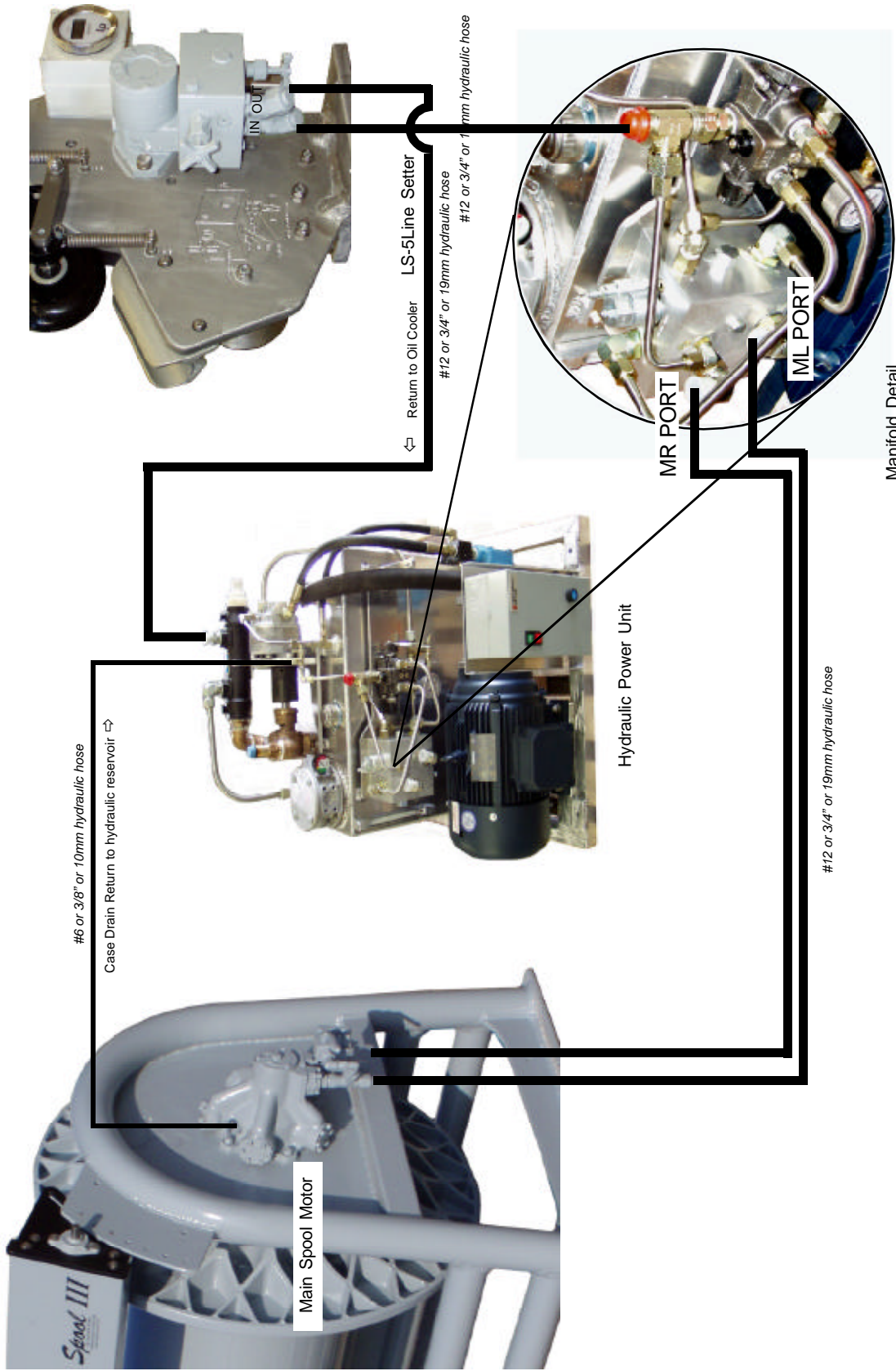



**LINDGREN-PITMAN  
TWIN SUPER SPOOL III  
Hydraulic Schematic**

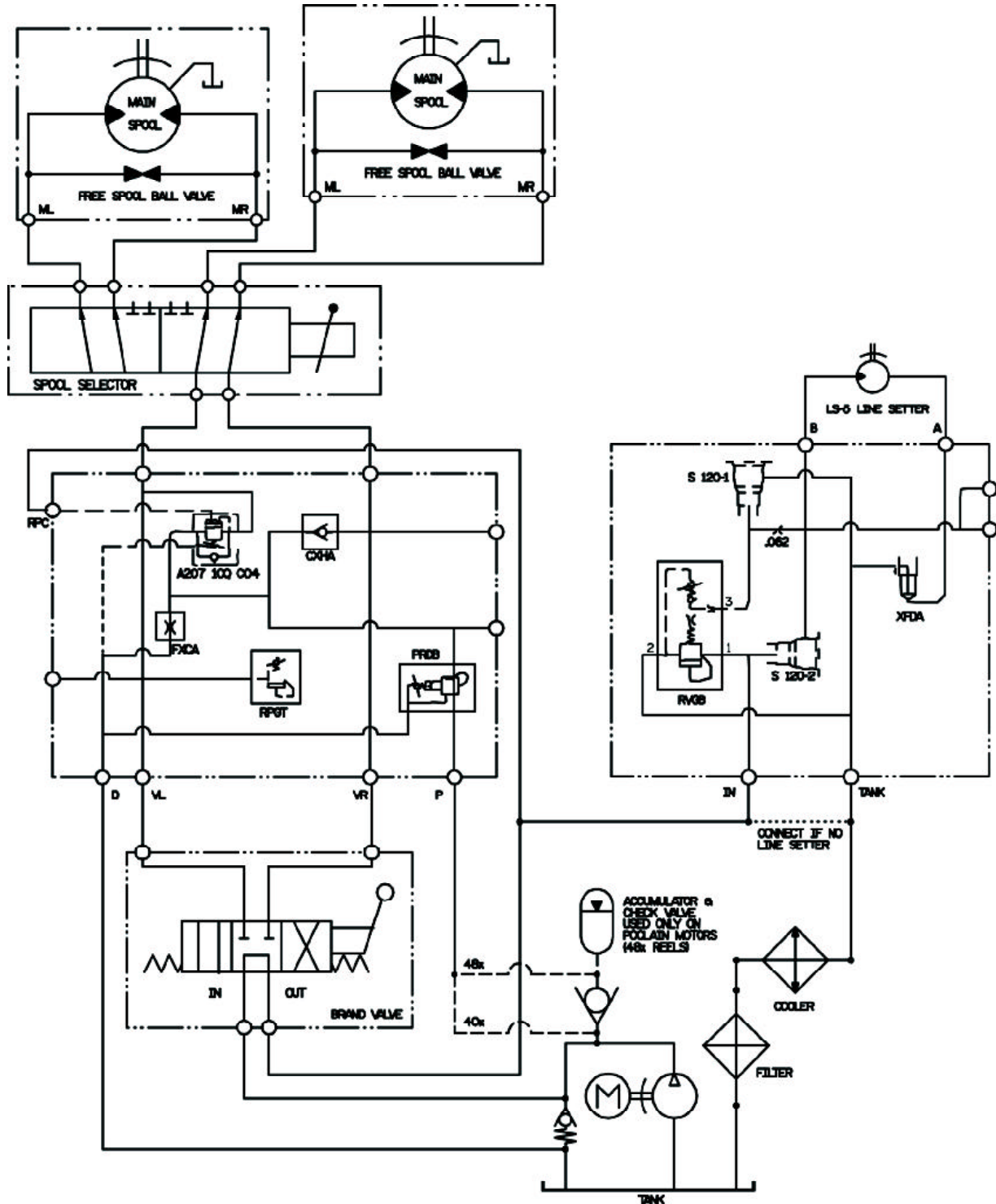

**LINDGREN-PITMAN**  
**Twin Super Spool III**  
**Longline Spool Hydraulic Circuit Connections**

